

Ohyelx

USER MANUAL



FAST ZIRCONIA SINTERING FURNACE

OY7 Max

Table of Contents

1 General Information	01	6 Cleaning and Maintenance	10
1.1 Limitation of liability	01	6.1 Cleanning	10
1.2 Responsibilities of the operator	01	6.2 Daily checks	10
2 General Safety Instructions	01	6.3 Replaced heating element	10
2.1 Safety Instructions	01	6.4 Replaced thermocouple	10
2.2 Requirements for personnel	01	7 Troubleshooting	11
2.3 Symbols & Warnings	01	8 Warranty and Repairs	12
3 Transport, packaging and storage	02		
3.1 Transport	02		
3.2 Packaging	02		
3.3 Storage	02		
3.4 Installation	02		
4 Product Specifications	03		
4.1 Delivery Scope	03		
4.2 CE Declaration of Conformity	03		
4.3 Intended Use	03		
4.4 Components & Interfaces	04		
4.5 Technical data	06		
4.6 Overall Dimensions	06		
4.7 Functional Description	06		
4.8 Replaceable Parts	08		
5 Sintering Programs	09		
5.1 Program overview	09		
5.2 Select Favorite Program	09		
5.3 Edit program	09		
5.4 Start program	09		
5.5 End program	09		

1. General Information

1.1 Limitation of liability

The content of this operating manual has been created taking the applicable laws and standards into account.

The unit has been developed using state-of-the-art technology

NOTE

The manufacturer assumes no liability for damage resulting from:

- Disregard/non-observance of the operating manual
- Intentional misuse
- Use other than as intended
- Operation by untrained personnel
- Operation by lay persons
- Technical modifications to the unit that have not been agreed with the manufacturer
- Use of replacement parts that have not been approved by the manufacturer

1.2 Responsibilities of the operator

The unit is used for commercial purposes. The operator of the unit is therefore subject to the statutory obligations relating to occupational safety.

In addition to the safety instructions in this operating manual, the regulations on safety, accident prevention and environmental protection that apply to the unit's field of use must be complied with.

In particular, the following apply:

- The operator must be familiar with the applicable occupational safety regulations.
- The operator must ensure that all employees who use the unit have read and understood this operating manual.
- The operator must ensure that all employees who use the unit have read and understood this operating manual.
- The operator must provide personnel with the necessary protective equipment.
- The operator must have all safety devices checked regularly for operability and completeness.

2. General Safety Instructions

2.1 Safety Instructions

The Ohyelx Furnace is a high-temperature furnace for commercial use in dental laboratories and may be used only for sintering sinterable ceramics.

2.2 Requirements for personnel

Trained and qualified personnel who know how to use the unit and whose specialist training, skills, experience and knowledge of the relevant regulations enables them to carry out the tasks assigned to them independently and recognise and avoid potential hazards.

2.3 Symbols & Warnings



DANGER

Electricity! Risk of death from electric shock.

- Do not touch live cables and components with wet hands.
- Observe the accident-prevention regulations when working with electric current.
- Before carrying out any installation, maintenance, cleaning or repair work, disconnect the power supply of the sintering furnace



WARNING

Risk of burns from hot surfaces!

The surfaces of the sintering furnace get hot during operation. These may cause burns if touched.

- Do not touch the housing or the furnace door during operation
- Do not reach into the heating chamber. It may still retain a high level of residual heat from the previous heating process.
- Ensure that the furnace has cooled down before carrying out maintenance, cleaning and repair work.
- Wear heat-resistant safety gloves if it is necessary to carry out work on hot components.
- Use a suitable and long pair of tongs to place items to be sintered into the furnace and adjust location.



CAUTION

Pinch Point!

Indicates a potentially dangerous situation that may cause minor physical injury.



CAUTION

A potentially hazardous situation that may cause damage to the product or surrounding property.



NOTE

A normal status indication that informs the current state of the device.



WARNING

Device Fault! Please Inspect and Resolve Immediately.



NOTE

A program note, requires further action

3. Transport, packaging and storage

3.1 Transport



CAUTION

Warning: Furnace Weight Can Cause Injury!

- At least two people are required to lift or move the sintering furnace.
- When working on live equipment, please follow the accident prevention regulations.



CAUTION

Please take care to avoid damage during transportation.

- Check for damage or missing items immediately upon receipt. The company accepts no liability for damages or losses found afterward.
- This equipment must be transported in an upright position.
- Do not stack multiple units.
- Do not place any heavy objects on the equipment.
- To prevent damage, avoid severe vibration or shaking during transport.

3.2 Packaging



CAUTION

The company uses specialized packaging to protect the sintering furnace from transport damage, corrosion, and other types of damage. After unpacking and inspecting the equipment, if it will not be used immediately, it is recommended to repack and store it in a dry place for future use.

3.3 Storage



CAUTION

To prevent damage due to improper storage, the following storage conditions are recommended:

- Once the equipment has been inspected and found to be intact, store it in the original packaging.
- Keep the equipment at an ambient temperature of +5°C to +40°C.
- Keep the equipment dry and free from dust at all times.
- Avoid Direct Sunlight.
- Avoid Mechanical Shock.

3.3 Installation



CAUTION

To avoid equipment damage from incorrect installation, ensure the following installation requirements are met:

- The furnace is for use only in a dry, enclosed indoor environment.
- During operation, the ambient temperature is recommended to be between 5°C and 40°C; avoid large temperature fluctuations.
- Ensure the furnace is placed on a non-combustible floor to avoid fire from hot material falling from the furnace.
- Install the furnace in a well-ventilated area to allow heat and exhaust gases to escape.
- If possible, the furnace should be placed under an exhaust duct or hood.
- Furnace weight: approx. 19 kg – Ensure installation surface can support it.
- The furnace must be installed on a flat, non-combustible surface or base.
- Leave at least 50 cm of lateral clearance on the sides, back, and top of the furnace; if adjacent to non-combustible materials, the lateral clearance can be reduced to 35 cm.



CAUTION

Due to the cost and fragility of the heating element, only trained and qualified personnel should install or service it.

4. Product Specifications

4.1 Delivery Scope

- OY7 MAX FURNACE X1
- Heating Element x 1
- Main Cable x 1
- Wifi Connector x 1
- Other Accessories
 - Metal Tweezers x 1
 - Allen Key x 1
 - Stylus Pen x 1
 - Double-Ended Wrench x 1
 - Metal Cooling Tray x 1
 - Crucible x 2

Upon receipt of the product, please unpack it immediately and inspect the machine for completeness and any possible transport damage. If any transport damage is found, please contact your supplier immediately for confirmation.

4.2 CE Declaration of Conformity

This product has been designed and manufactured in strict accordance with harmonized standards and additional technical specifications. It therefore complies with the latest state of the art and ensures the highest level of safety. In terms of design and performance, this product fully complies with European directives and applicable national supplementary requirements, as confirmed by the CE marking.

The following standards apply:

- EN ISO 12100:2010
- EN 60204-1:2018
- EN IEC 60519-1:2020
- EN IEC 61000-6-2:2019
- EN IEC 61000-6-4:2019
- EN IEC 61000-3-2:2019+A1:2021
- EN 61000-3-3:2013+A2:2021+AC:2022

4.3 Intended Use

The Ohyelx rapid sintering furnace is a high-temperature furnace intended for the sintering of zirconia ceramics in commercial and laboratory applications. It is permitted for use only in the sintering of sinterable ceramics, in particular zirconia materials.

IMPORTANT NOTE

The manufacturer shall not be held liable for any damage resulting from the product being used for purposes other than those specified, from incorrect operation, improper connections, or unprofessional maintenance or repair performed by untrained personnel. Furthermore, all warranty services shall be void under the following circumstances.

Possible Misuse Cases:

- Use of spare parts not approved by the manufacturer.
- Technical modifications or alterations to the equipment without the manufacturer's authorization.
- Handling products or hazardous materials not specified by the manufacturer.
- Operation by unqualified or untrained personnel.

Materials used in the furnace must be verified to ensure they are not corrosive and will not damage the insulation or heating elements.

Do not remove, bypass, or disable any safety devices.

The installation instructions and safety regulations must be strictly followed; otherwise, the product will be considered used outside its intended purpose, and the manufacturer shall not be held liable.

4.3 Components & Interfaces

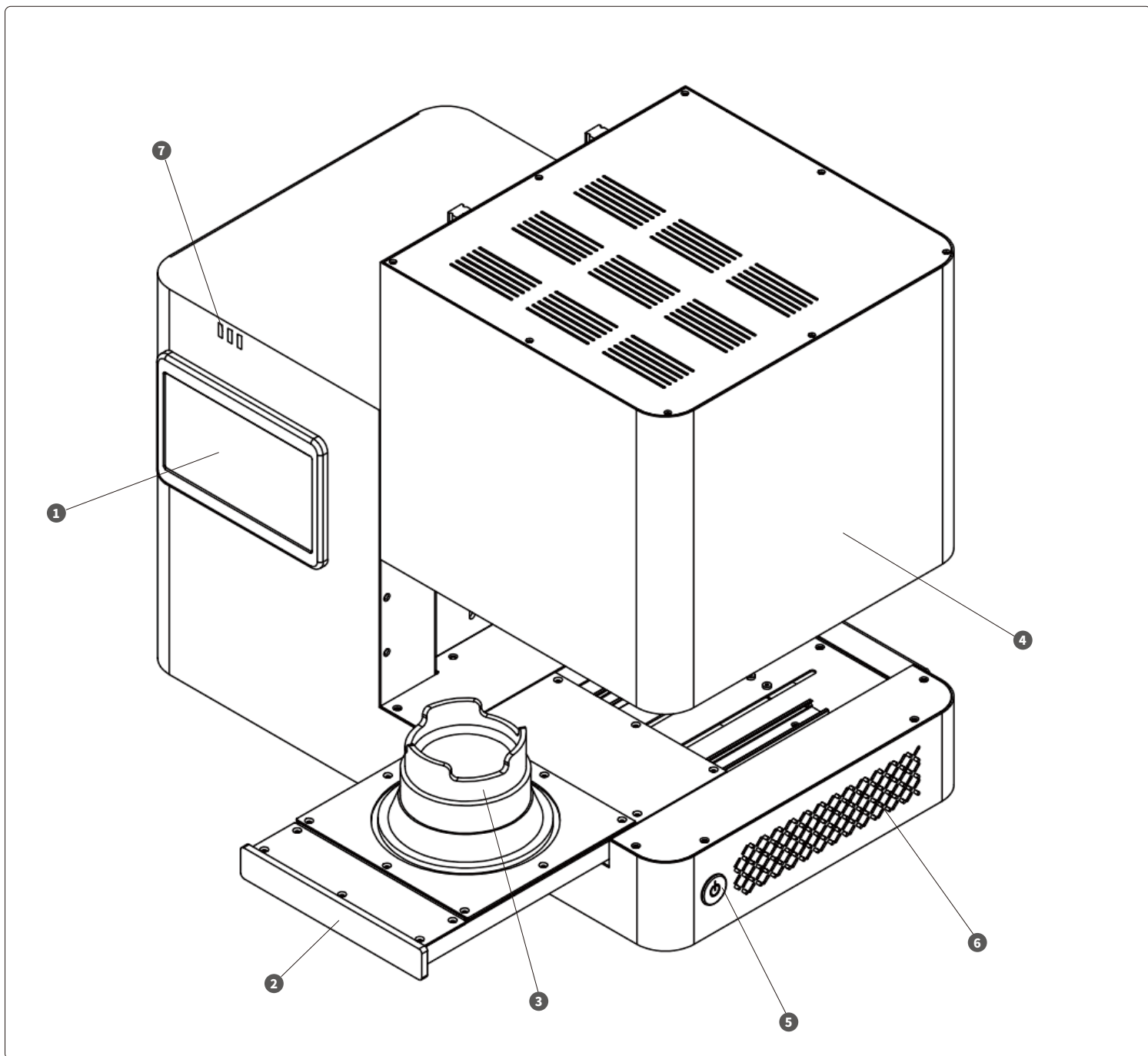

Fig.1 Machine overview, Front

- ① 7" Operational display
- ② Front/Rear Platforms
- ③ Crucible
- ④ External Shell
- ⑤ Mains switch
- ⑥ Fans

- ⑦ Status Indicator Light
 - White: Standby Mode
 - Green: Heating Mode
 - Yellow: Cooling Mode
 - Red: Fault Mode
 - Blue: Preheating Mode

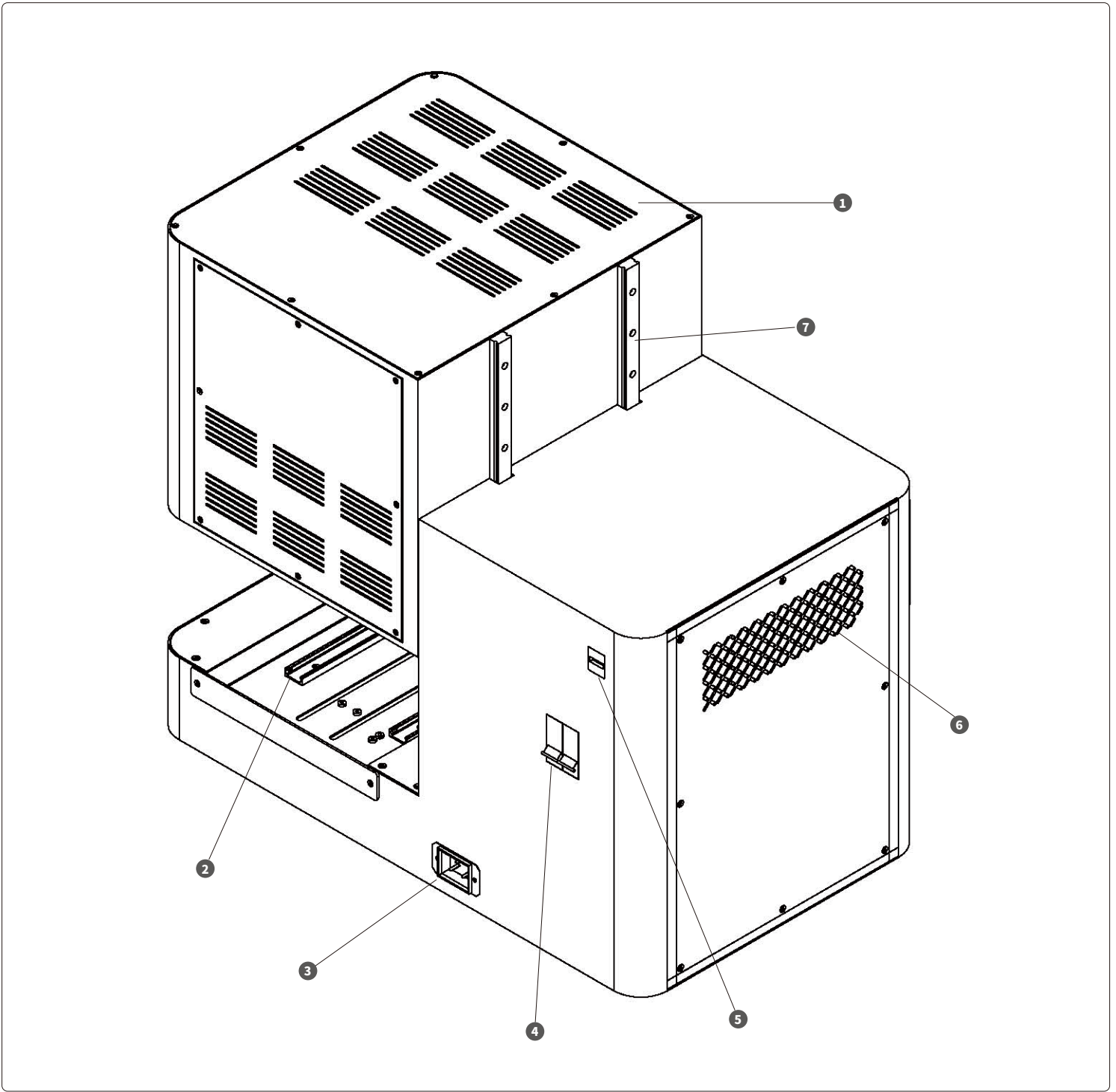

Fig.2 Machine overview, Back

- ① Top Maintenance Panel
- ② Front and Rear Rails
- ③ Power supply connection
- ④ Circuit breaker
- ⑤ USB port/Wireless port
- ⑥ Fans
- ⑦ Upper and Lower Rails

4.5 Technical data

Size(LxWxH)	555x350x365mm
Net Weight	37kg
Rated Power	3500W
Power Supply	220-240V, 50/60 Hz
Sintering Chamber Size (DiameterxHeight)	∅100mm x 70mm
Max Temperature	1600°C
Crucible Type	Double-layer Crucible
Heating Rate	≤80°C/min
Heating Element	Silicon Carbide Heater

4.6 Overall Dimensions

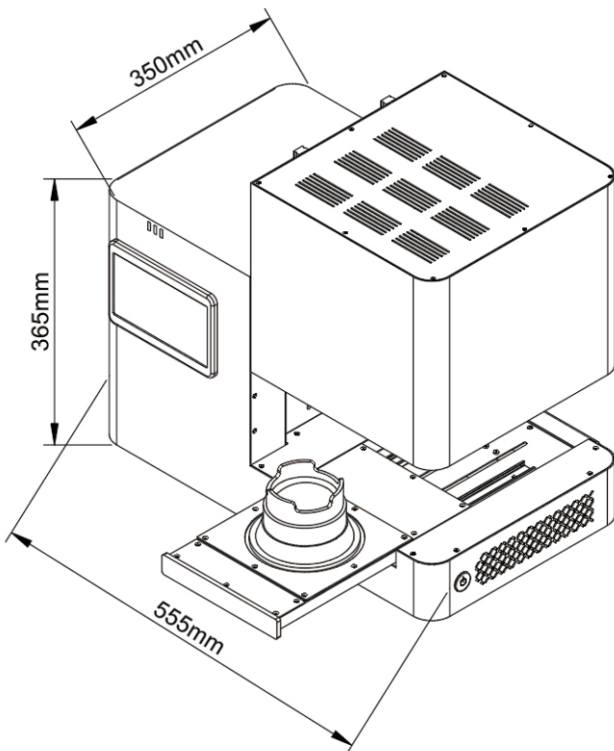

Fig.3

4.7 Functional description



Fig.4 Standard Display Interface

- | | |
|-------------------------------|----------------------|
| ① Program Selection | ⑪ Date, Time |
| ② Total Duration | ⑫ Server Connected |
| ③ Program Maximum Temperature | ⑬ WIFI Connected |
| ④ Real-Time Voltage | ⑭ Back to Settings |
| ⑤ Real-Time Current | ⑮ Program Setting |
| ⑥ Preheating / Start | ⑯ Standard Interface |
| ⑦ Program Chart | ⑰ Door Open |
| ⑧ Remaining Time | ⑱ Pause |
| ⑨ Device Status | ⑲ Door Closed |
| ⑩ Real-Time Temp | ⑳ Start Program |
| | ㉑ Stop Program |



Fig.5 Settings Interface

- ① System Settings
- ② Temperature Settings
- ③ Language Settings
- ④ Device Info
- ⑤ Record Query

4.7.1 System Settings

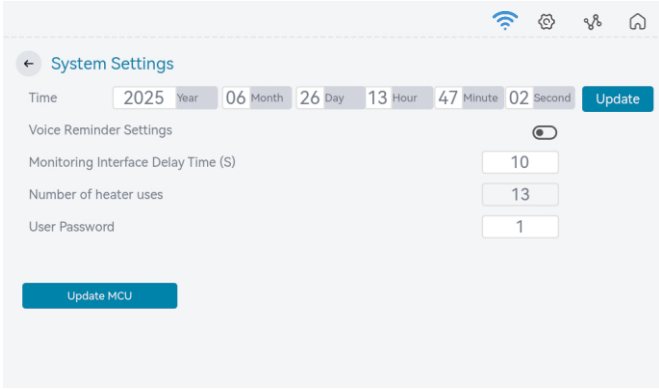

To upgrade the system, first download the upgrade program and save it to the root directory of a USB flash drive. Insert the USB drive into the port shown in Figure 2 ⑤. Then, in the System Settings interface, tap "Update MCU". Wait for the upgrade to complete, and then restart the system.
 User Password: Set the operation password to ensure operational security.

4.7.2 Temperature Settings

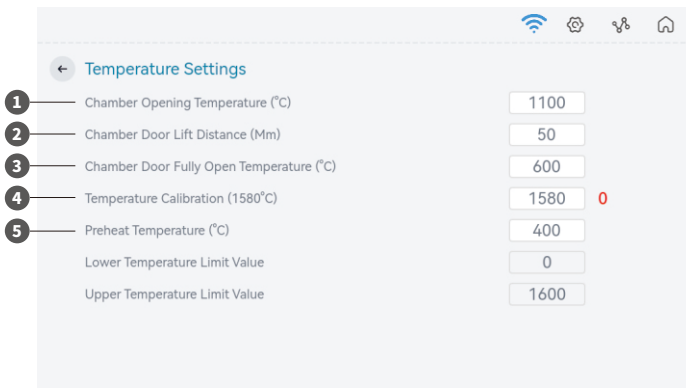

- ① Door Open Temp.: Upon completion of the sintering cycle, once the furnace cools to this setpoint, the door will open to a specific gap defined by Parameter ②.
- ② Door Lift Distance (mm): Determines the opening distance of the chamber door.
- ③ Full-Open Setpoint: The chamber door opens completely when the furnace cools down to this temperature.
- ④ Temperature Calibration: After calibrating the temperature, set the calibration temperature here. For instructions on how to perform temperature calibration, please refer to the following video tutorial: (Note: Temperature calibration has been performed prior to factory delivery.)



- ④ Preheating Temperature: If the preheating temperature needs to be set, it can be configured here.

4.7.3 Language Setting

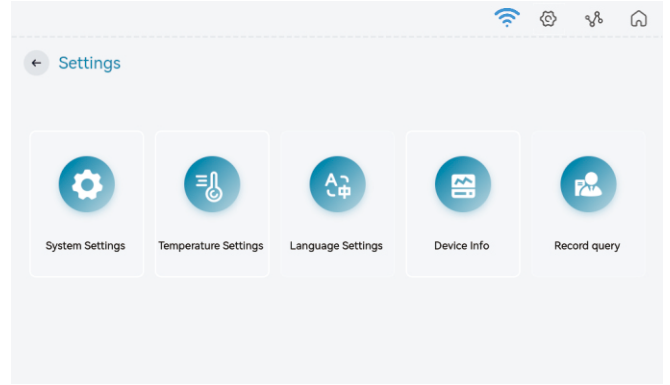

The Ohyelx operating system supports 10 different language settings: Chinese, English, Japanese, French, Spanish, Italian, German, Korean, Russian, and Arabic.

4.7.4 Device Info

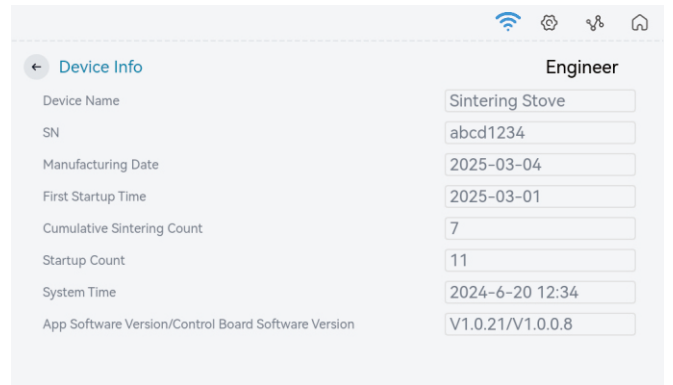

In the device information interface, details such as the sintering furnace's manufacturing date, serial number, and cumulative sintering cycles can be viewed.

4.7.5 Record Query

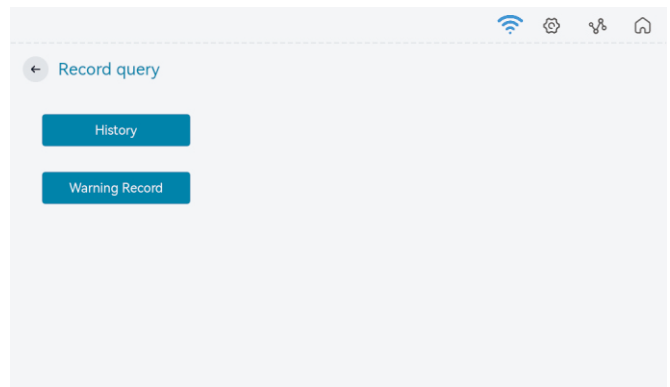

In the Record Query module, Historical Records and Alarm Records can be viewed.

4.8 Replaceable Parts

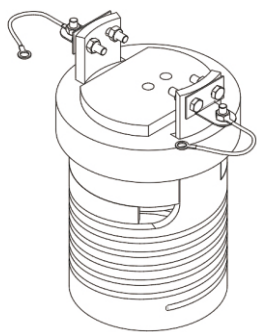

OY7 MAX HEATING ELEMENT KIT

Product Code: OYM202510001

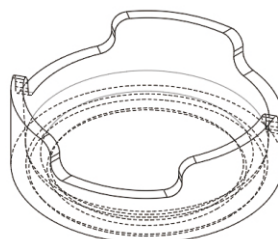

OY7 MAX CRUCIBLE

Product Code: OYM202510006

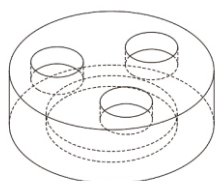

OY7 MAX CRUCIBLE BASE

Product Code: OYM202510002

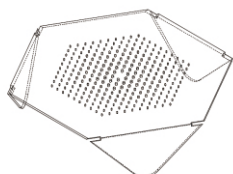

METAL COOLING TRAY

Product Code: OYM202510003

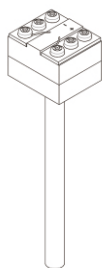

TYPE B THERMOCOUPLE

Product Code: OYT202510004



METAL TWEEZERS

Product Code: OYT202510005

5. Sintering Programs



NOTE
The operation display is designed as a touchscreen. During operation, the corresponding symbols on the screen must be touched fully.

5.1 Program Overview

The Ohyelx fast sintering furnace supports up to 32 programmable curves, displayed as 8 curves per page across 4 pages. All curves are fully customizable.

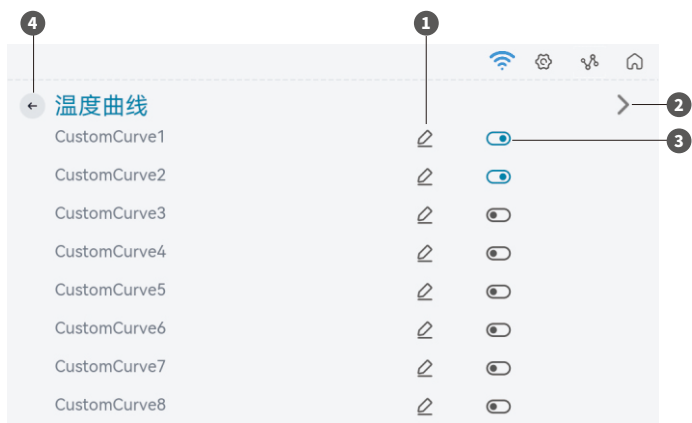

Fig.6 Program List

5.2 Select Common Programs

If only a limited number of programs are required, toggle the corresponding program switches (Fig. 6 3). When the switch turns green, tap "Return/Save" (Fig. 6 4). These program are now activated and can be selected on the main interface (Fig. 4 1).

5.3 Edit Program

Tap the icon 2 corresponding to the program to edit it. The program editing interface is shown below:

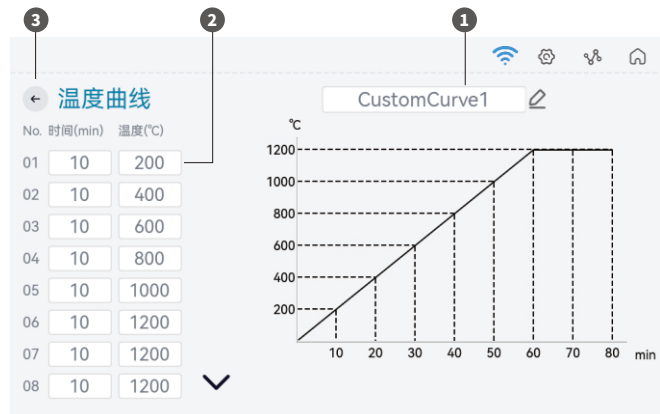
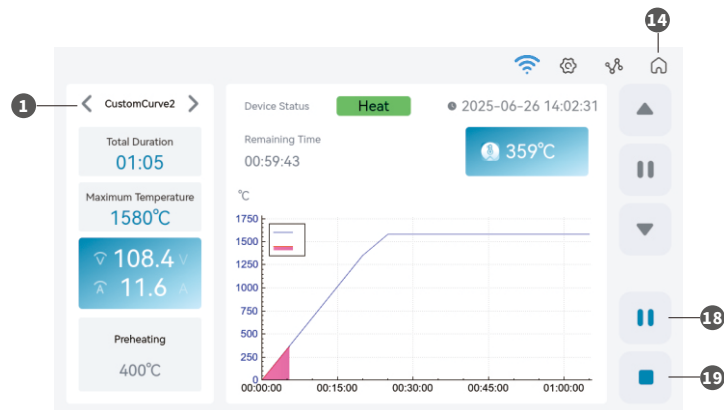

Fig.7 Program Edit

- 1 Program Name: Supports numbers and English letters only.
- 2 Each program supports up to 15 segments, which can be configured by the user as needed.
- 3 Once the program settings are complete, simply click Fig.7 3 to save.

5.4 Start Program

After setting the program, return to the main interface 14 and select the corresponding sintering program 1. Ensure the furnace door is closed, then press the 18 button to begin the sintering process.



5.5 End Program

To stop the sintering process, simply click button 19.

6. Cleaning and Maintenance

6.1 Cleanning

Use a neutral detergent to clean the furnace exterior periodically.



NOTE

Please take care to avoid damaging the furnace!

- Do not use high-pressure cleaners or compressed air for cleaning.
- Use only non-flammable, water-based or solvent-free commercial cleaners.
- Please contact the manufacturer if you are unsure about the compatibility of any cleaning agent.
- Residual dyeing liquids may significantly shorten the service life of the heating elements.

Before cleaning, please ensure:

- Unplug the power plug!
- Allow the furnace to cool down to room temperature!
- Please refer to Fig.8 below for recommendations on cleaning the various parts!

Part	Cleaning Method
Furnace Housing	Wipe with a damp soft cloth
Furnace Chamber	Carefully vacuum out
Insulation Material	Carefully vacuum out
Touchscreen	Wipe with a damp soft cloth

Fig.8 Cleaning Way

6.2 Daily checks

- Check the furnace housing for external damage.
- Check the functionality of safety devices (e.g., power switch, circuit breaker).
- Check for abnormal noise.

Visually inspect the following components:

- Sealing integrity of the furnace door and housing
- Visible parts of the heating elements inside the furnace
- Visible parts of the thermocouple inside the furnace

6.3 Replaced heating element

When a heating element reaches the end of its service life or malfunctions, please refer to the following video guide for replacement instructions.



NOTE

As the heating elements are expensive and fragile, their installation and repair must be performed by trained and qualified personnel.

6.4 Replaced thermocouple

When the thermocouple reaches the end of its service life or malfunctions, please refer to the following video guide for replacement. The preparatory steps for the thermocouple are identical to those for the heating elements. Please pay strict attention to the polarity (positive and negative) of the connections; do not reverse them.



7. Troubleshooting



WARNING

If a malfunction occurs during operation, please inspect and troubleshoot the issue promptly!

Fault Description	Possible Cause	Solution
GS40 ERROR 0: PLEASE CHECK	GS40 Internal Fault	Troubleshoot according to GS40 fault codes or replace the unit.
MOTOR OR SENSOR ERROR. PLEASE CHECK.	<ol style="list-style-type: none"> 1. Check the connection ports to the mainboard. 2. Motor or sensor failure. 	Check the ports; replace the motor or sensor.
FAN ERROR. PLEASE CHECK.	<ol style="list-style-type: none"> 1. Check the connection ports to the mainboard. 2. Fan failure. 	Check the ports or replace the fan.
HEATING ELEMENT ERROR. PLEASE CHECK.	<ol style="list-style-type: none"> 1. Heating element broken or burnt out. 2. Blown fuse. 3. GS40 failure. 	Identify the faulty part. Replace the heating element, fuse, or Gs40.
FURNACE TEMPERATURE TOO LOW. PLEASE CHECK.	The furnace temperature is below the lower limit alarm value.	Set the lower temperature alarm limit (default: 0°C).
FURNACE TEMPERATURE TOO HIGH. PLEASE CHECK.	The furnace temperature exceeds the upper limit alarm value.	Set the upper temperature alarm limit (default: 1600°C).
THERMOCOUPLE ERROR 0. PLEASE CHECK.	Thermocouple failure.	Confirm the thermocouple is damaged and replace it.

8. Warranty and Repairs



NOTE

Each unit has been factory-tested and test-run by the manufacturer. The test run may cause discoloration of the furnace chamber or components, which is a normal phenomenon.

Limited Warranty: The Seller warrants that the new products sold hereunder will be free from defects in material and workmanship under normal use and service. Under this warranty, the Seller's obligation is limited to the repair or replacement, at the Seller's sole option, of any product proved to be defective in material or workmanship within one year from the date of delivery.

The Seller assumes no liability for failure of the Seller's product, in whole or in part, resulting from the use of products or components not manufactured by the Seller, or from defects relating to designs, labels, or manufacturing specifications supplied by the Buyer.

The Seller's liability for all claims, whether based on breach of contract, negligence, product liability, or otherwise relating to the product, shall not exceed the amount paid by the Buyer under this contract. In no event shall the Seller be liable for any punitive, special, incidental, or consequential damages (including but not limited to loss of use, loss of profits, and third-party claims), however caused, and whether or not resulting from the Seller's negligence.

Inspection: The Buyer shall inspect the products immediately upon receipt. The Buyer shall notify the Seller in writing of any claims for defects in material and workmanship within 10 days after the Buyer discovers or should have discovered the facts giving rise to such claims. Failure by the Buyer to give written notice of such claims within such period shall be deemed a waiver of such claims.

This warranty does not apply to products that have been subject to misuse, negligence, accident, improper installation, unauthorized modification, or repair by unauthorized personnel. Furthermore, liability claims for personal injury or property damage are excluded if attributable to one or more of the following causes:

- The manufacturer assumes no liability for damage or operational interruptions caused by failure to observe these instructions. All personnel must read and understand this manual before operation.
- Use of the Ohyelx sintering furnace contrary to the operating instructions.
- Improper installation, start-up, operation, or maintenance of the furnace.
- Operating the furnace with defective safety equipment, or with improperly installed or inoperative safety protection devices.
- Failure to observe the information in the operating instructions regarding transport, storage, installation, start-up, operation, and maintenance.
- Unauthorized modifications to the furnace.
- Unauthorized changes to system settings or parameters.
- Unauthorized modifications to parameterization, settings, or programs.
- Ohyelx assumes no liability for damage caused by the use of non-original parts. Original parts and accessories are designed specifically for Ohyelx furnaces. Please use only original Ohyelx parts for replacement. Failure to do so will void the warranty.
- Disasters caused by third parties or Force Majeure.

Ohyel Intelligent Equipment Co.,Ltd

Add:No.83, Minying Road, Dainan Town,
Xinghua City, Jiangsu Province, China

Mob:+86 13625192728

Email:info@ohyelx.com

www.ohyelx.com

